

DIGI-LOG™ REVERB MODULE (BTDR-1)

A great digital reverb sound that easily replaces a spring reverberation unit



Pat. No. : US 8,204,240
CN ZL200880021110.9

Features

- Simple interface requires only input, output, +5V, and ground
- Available in horizontal or vertical mounting
- Pin-compatible with BTSE-16FX Digital Effector
- AC-coupled input and output require no external capacitors
- RoHS compliant

Specifications

Parameter	Symbol	Minimum	Typical	Maximum	Unit
Supply Voltage	V_{CC}	4.5	5.0	5.5	V
Supply Current	I_{CC}		60	100	mA
Input Voltage	V_{IN}			1.5	V_{PEAK}
Voltage Gain			0		dB(>10k Ω load)
Residual Noise			-80	-72	dBV
Input Impedance	Z_{IN}		10k		Ω
Output Impedance	Z_{OUT}		220		Ω
Operating Temperature		-40		+85	C

Subject to change without notice

Available Options

Type	Decay		
	S	M	L
Type	short	medium	long
Time(T_{60})	2.0 s	2.5 s	2.85 s

Ordering code

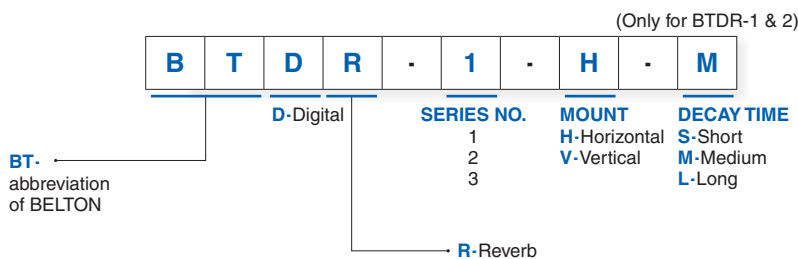

DIGI-LOG™ REVERB MODULE (BTDR-1)

Connection Diagram

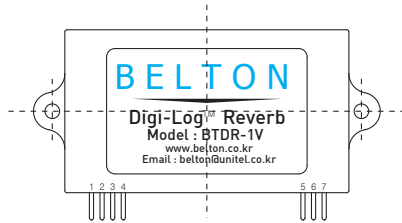

- | | |
|-----------------|----------------|
| 1. V_{OUT} | 5. GND (Power) |
| 2. V_{OUT} | 6. N.C. |
| 3. GND (Signal) | 7. V_{CC} |
| 4. V_{IN} | |

Note Pins 3 and 5 are internally connected. It using a common ground for signal and power supply, connected only pin 5 and leave pin 3 unconnected.

BTDR-1H Horizontal mount

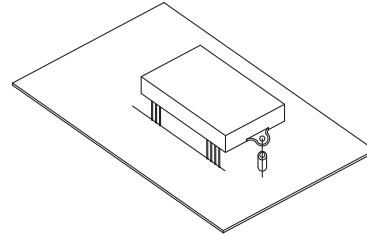

BTDR-1V Vertical mount

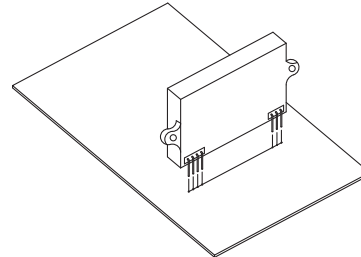

Dimensions

BTDR-1H

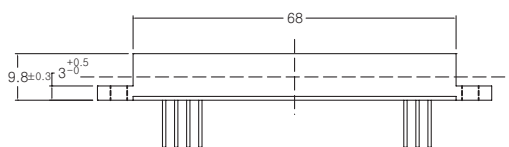
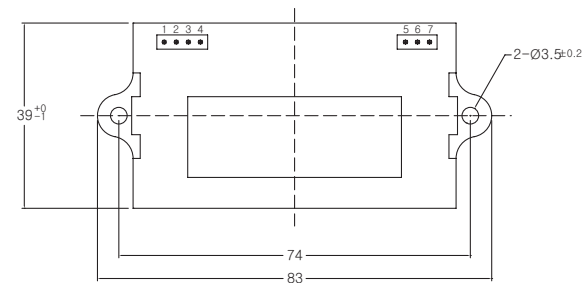

MOUNTING HOLES

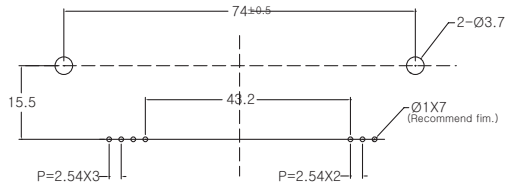

BTDR-1V

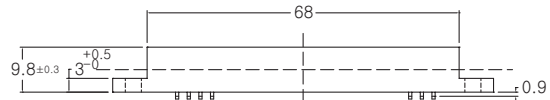
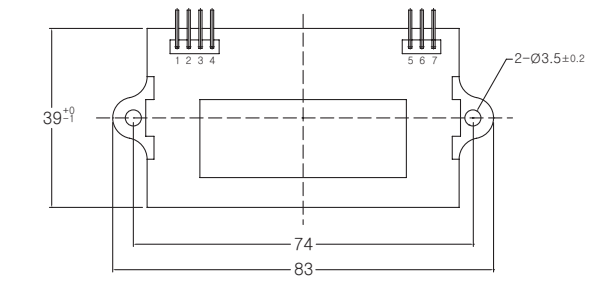

MOUNTING HOLES

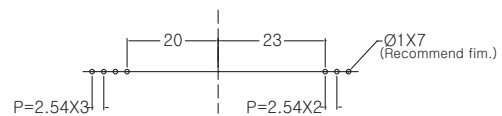

DIGI-LOG™ REVERB MODULE (BTDR-1)

Application Circuit

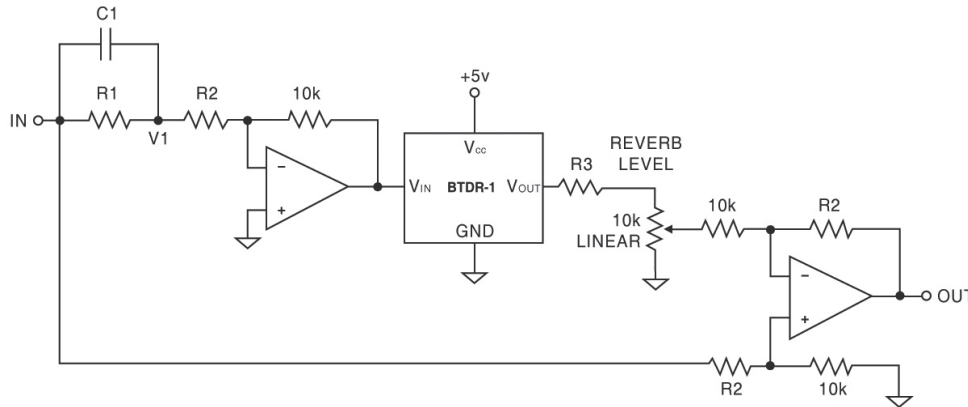

- The value of R2 sets the proper input level to the BTDR-1. Set $R2 = 6.7k\Omega \cdot V_1$, where V_1 is the maximum peak voltage measured at node V_1 shown in the schematic above.
- C1 and R1 are optional and create a high-pass or shelf filter that attenuates the low frequency input to the reverb.
 - For a low shelf filter :
 - Set $C1 = 1/(2\pi \cdot R2 \cdot f_c)$, where f_c is the shelf frequency.
 - Set $R1 = R2 \cdot (1 - G_s)/G_s$, where G_s is the shelf gain.
 - For a high-pass filter :
 - Set $C1 = 1/(2\pi \cdot R2 \cdot f_c)$, where f_c is the cutoff frequency.
 - Omit R1 ($R1 = 0$)
- Adjust R3 to limit maximum reverb level. R3 may be omitted for maximum reverb level.
- The use of a regulated 5V supply, such as a 78L05, is highly recommended. A ceramic bypass capacitor may be necessary between V_{cc} and GND if the regulator is not close to the reverb module.
- Audio noise during power-down can be minimized by quickly discharging supply from 5V to 0V; otherwise, external output muting is recommended.

Example : Configure the circuit above for a shelf filter with $f_c = 200$ Hz and 10 dB attenuation when the Maximum voltage at $V_1 = 8V_{pk}$.

- $R2 = 6.7k\Omega \cdot 8V = 53.6k\Omega$
- $C1 = 1/(2\pi \cdot 53.6k\Omega \cdot 200Hz) \approx 0.015\mu F$
- $G_s = 10^{(-10dB)/20} = 0.316$
- $R1 = 53.6k\Omega \cdot (1 - 0.316)/0.316 \approx 115k\Omega$

Considerations for FCC Compliance

- No high-frequency clocks are conducted outside of BTDR-1's internal ICs, minimizing emissions.
- Use of the BTDR-1V (vertical mounting) should lower conducted emissions, since it eliminates parallel signal paths between the BTDR-1, and main interface PC board
- No guarantees of FCC compliance are made for the BTDR-1, as it has not been tested for radiofrequency emissions, either radiated or conducted.